

# Influence of prefabricated post screw head design on the stress pattern in the core and crown. Finite element stress analysis study



Sulaimani Dental Journal

Abdulsalam R Al-Zahawi<sup>1</sup>

<sup>1</sup> B.D.S, HDD, M.Sc, Ph.D (Conservative Dentistry). Lecturer of Conservative Dentistry. Department of Conservative Dentistry, School of Dentistry, Faculty of Medical Science, University of Sulaimani, Iraq.

## Abstract

**Objectives:** This study evaluated the influence of dental post head design on the stress distribution in the core and crown structure as an in vitro study.

**Materials and Methods:** 3D finite element model prepared for three different stainless steel post head designs (rectangular with sharp line angle (A), rectangular with fillet line angle (B), and post with round head (C), inserted in single rooted tooth and retained the composite core and zircon crown. Two configurations of load (100) Newton were applied vertically (V) and lateral oblique (LO) on the occlusal surface of the crown. The results were analyzed and the maximum Von Mises stress option of the stress analysis, at the core and crown parts were compared.

**Results:** The results shown that the Maximum Von Mises stresses value in design A (45.58, 186.16) MPa, design B (44.48, 183.71) MPa and design C (29.31, 12984) under V load and LO load in sequence. The maximum Von Mises stress location was at the cervical margin of the crown, in design A and B, while located at the top surface of the core for design C under both load configurations. The stresses were concentrated at the top surface of the core in designs A and B, whereas, the stress pattern distributed uniformly in the core structure for design C.

**Conclusions:** The round post screw head design produces more benign stress distribution under different occlusal load compared with rectangular shape particularly at the crown margin.

**Keywords:** Post head, finite element, core and crown, stress patter; stress analysis.

## Correspondence to;

Dr. Abdulsalam R Al-Zahawi  
sazahawi@yahoo.com

Received: June, 2015

Accepted: August, 2015

Published: December, 2015

**Cite this article as:** Al-Zahawi AR. Influence of prefabricated post screw head design on the stress pattern in the core and crown. Finite element stress analysis study. Sulaimani Dent J. 2015;2(2):77-82.

## Introduction:

The root canal therapy saves the root whereas, restoration reinstates the tooth as a functional member of the masticatory system. The minimum treatment indicated for endodontically treated posterior teeth is the placement of cast restoration with coverage<sup>(1-2)</sup>. To accomplish this objective, the restorative procedure should be primarily concerned with the prevention of tooth fracture under occlusal forces on posterior teeth, which are predominantly vertical and lateral forces, Reinforcement of the coronal tooth structure is not commonly needed if there is adequate tooth structure and proper restoration is done after endodontic treatment<sup>(3-5)</sup>. Whereas, Pereira et al (2005) studied the effect of the remaining coronal structure on the resistance of teeth with intraradicular retainer, found that when the dental crown was not completely removed, the amount of remaining coronal dentin did not significantly affect the fracture strength of endodontically treated teeth<sup>(6)</sup>. Some clinicians believe that a post should be placed in the root after endodontic treatment to strengthen or reinforce it. Some studies, however, pointed out that the posts do not strengthen teeth, contrariwise the preparation of a post space and

the placement of a post can weaken the root and may lead to root fracture<sup>(7-10)</sup>. These studies further suggested that a post should be used only when there is insufficient tooth substance remaining to support the final restoration. In other words, the main function of a post is the retention of a core to support the coronal restoration<sup>(4)</sup>. The ideal post and core material should have physical properties similar to those of dentin, such as modulus of elasticity, compressive strength and coefficient of thermal expansion. The most common materials used to fabricate post screw are stainless steel, gold-plated brass titanium and titanium alloys, ceramic and fiber reinforced polymers<sup>(4)</sup>.

Different materials have been used to build up the core and investigate it, such as amalgam, composite and glass-ionomer<sup>(2,11)</sup>. Perhaps clinician can bond the post securely to the dentin in the root canal space, the core to the post and the final restoration to the core and the tooth by using new adhesive materials. However, most studies claim that a post can strengthen and reinforce the core build-up and extra-coronal prosthesis to the root and support the final restoration. No study,

investigate the post head shape influence on the stress distribution in the core and crown parts. Whereas, there are few studies investigated the influence of the post head shape on the retention of the core material<sup>(4,12,13)</sup>.

Since the head of the ready-made post designed with different shape to create optimum retention of the core restoration to the root. The goal of the present investigation is to optimize the post head shape that show the benign stress distribution under different occlusal load.

**Materials and Methods:**

Three prefabricated dental stainless steel post head designs and parallel taper end threaded posts inserted in single rooted teeth were simulated as a 3D model. The length and diameter of the threaded part of these three posts were 12 mm and 2 mm in sequence. The first post screw head design (A), was the rectangle with sharp line angle, second design (B) was a rectangular head with fillet line angle, and the third post screw design (C) was a round head as shown in Figure 1.

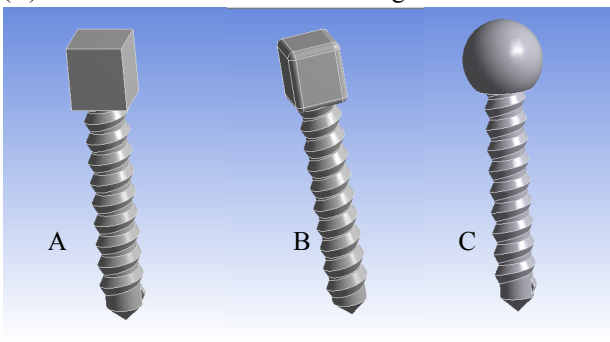

**Figure 1: Three different dental post screw head designs A) rectangle with sharp line angle, B) rectangular with fillet line angle, C) ball shape, applied in this study.**

The dimensions of the post head were (2.5 mm width x 2.5 mm depth and 2.5 mm height) for design A and B. Whereas (2.5 mm) diameter of the ball head shape for design C. Design Modular of Ansys 14 stress analysis software was used to develop these screw configurations and other model parts (single root canal root of upper second premolar, Gutta percha left at the apical third of the root, composite core and all ceramic zircon crown). The shape and geometry of the tooth structure were driven from dental anatomy textbook (14). Then the assembly was applied to the model parts in the Ansys 14 workbench software as shows in Figure 2. The interface, contact between model parts defined as a perfect contact.

All the materials and structures were considered linear elastic, homogeneous, and isotropic. Mechanical properties (modulus of elasticity and poissons ratio) of the model parts will be derived from materials scientific data in previous study (15). Two 100 Newton load configurations were applied vertically (V) and lateral oblique (LO) on the top of the crown as shown in Figure 3. All of the external surface area of the root was constrained in all directions. The 3D models were

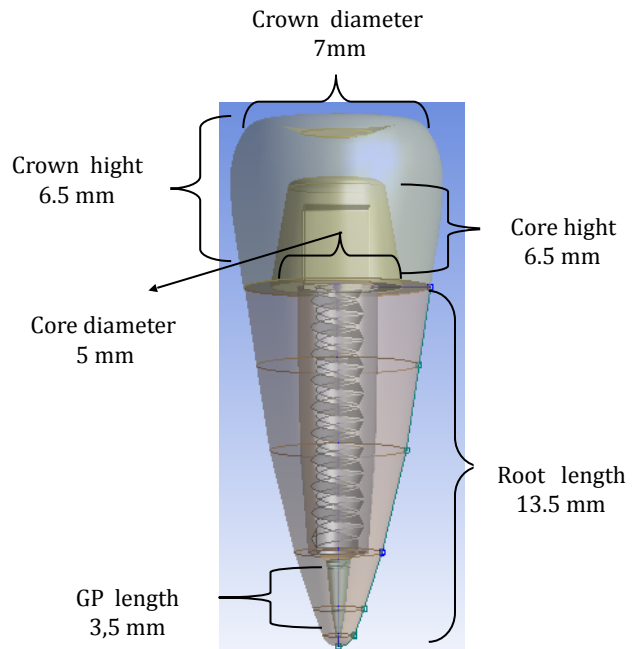

**Figure 2: Model design and dimension includes (root, post, core, and crown).**

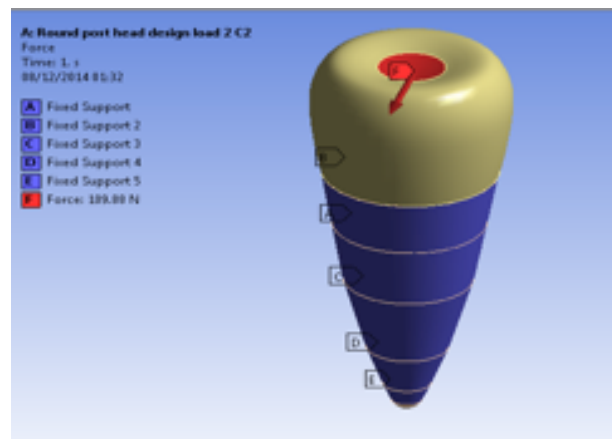

**Figure 3: Site of load applications and boundary condition.**

meshed and basic descriptive statistic analysis was applied to evaluate and compare the maximum Von Mises stress of the post product results option of the stress analysis, at the core and crown parts of the model.

**Results:**

Table (1) shows that there was no important difference in the Maximum Von Mises stresses value produced between design A (45.58, 186.16) MPa and design B (44.48, 183.71) MPa under V load and LO load in sequence. Whereas, both designs, produce higher von Mises stress under V and LO load compared with design C (29.31, 129.84) MPa. The maximum Von Mises stress location was at the cervical margin of the crown as shown in figures (4a,4b, 5a, 5b, 7a, 7b, 8a, and 8b) in design A and B. Whereas, The maximum

Von Mises stress was located at the top surface of the crown for design C under V load as shown in figures (6a and 6b), and between the screw head and its shaft under LO load as shown in figure (9a-9b). The Von Mises stress was concentrated at the top surface of the core in designs A and B, whereas, the stress pattern distributed uniformly in the core structure for design C under V load, it was similar under LO load, with some high stress concentration at the interface between the core the root structure.

**Discussion:**

However, searching the literatures to find an article linked to the influence of the dental post head design on the stress distribution and value in the core and crown restoration wasn't found. However, the majority of the articles were investigated the influence of the post design on tooth structure strength, few articles were published investigating the influence of the post head design on the core retention<sup>(10-13)</sup>. In this study 3D FE stress analysis method was used to investigate the influence of the dental post head design on the stress value and pattern in the crown and core. The results of

**Table 1: Maximum Von Mises stress results recorded according to each design.**

Design	Load direction	Maximum Von Mises Mpa	Location
A1	V	45,576	At the cervical crown margin
B1		44,48	At the cervical crown margin
C1		29,307	At the top of the head and distribute apically
A2	LO	186,16	At the cervical crown margin
B2		183,71	At the cervical crown margin
C2		129,85	At the site of load application

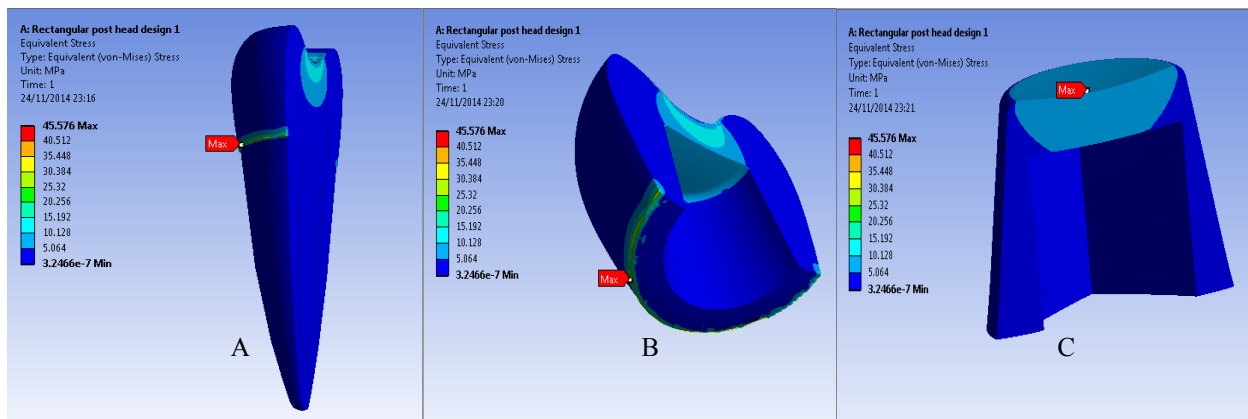

**Figure 4: Maximum Von Mises stress value and pattern of design (A) under V load; a) all model parts, b) crown, and c) composite core.**

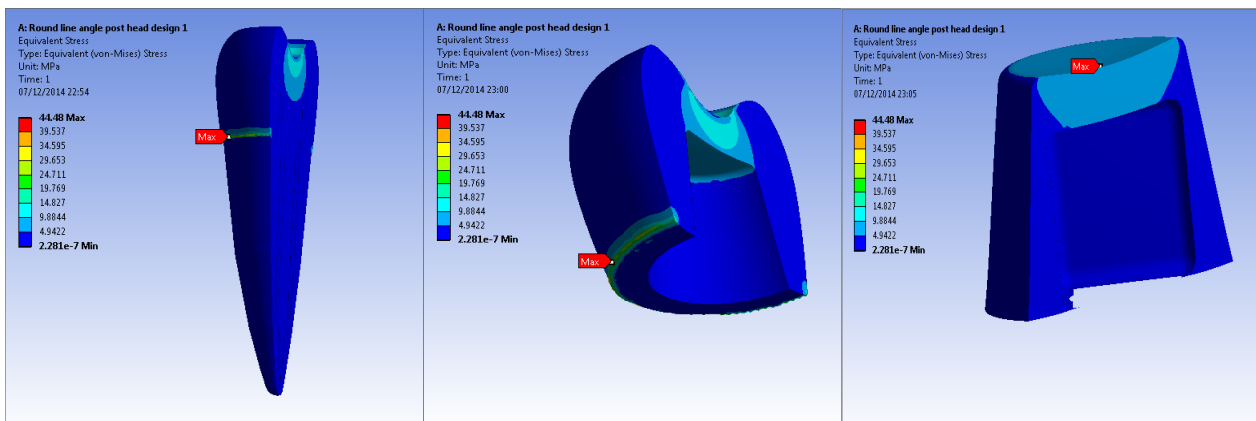

**Figure 5: Maximum Von Mises stress value and pattern of design (B) under V load; a) all model parts, b) crown, and c) composite core.**

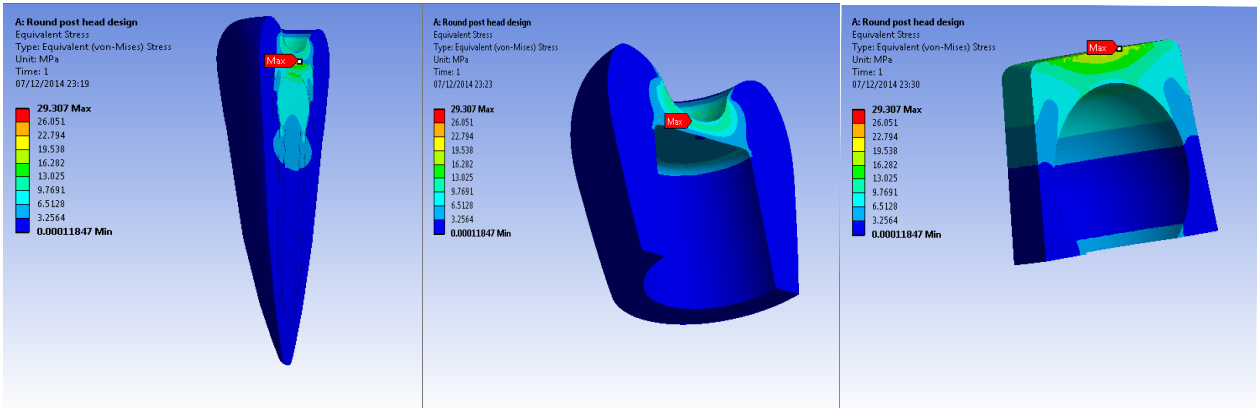

**Figure 6: Maximum Von Mises stress value and pattern of design (C) under V load; a) all model parts, b) crown, and c) composite core.**

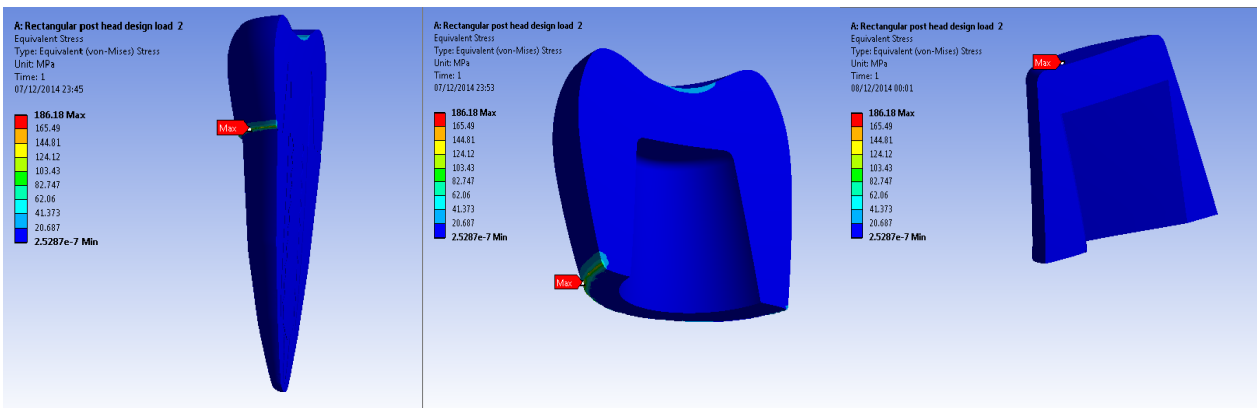

**Figure 7: Maximum Von Mises stress value and pattern of design (A) under LO load; a) all model parts, b) crown, and c) composite core.**

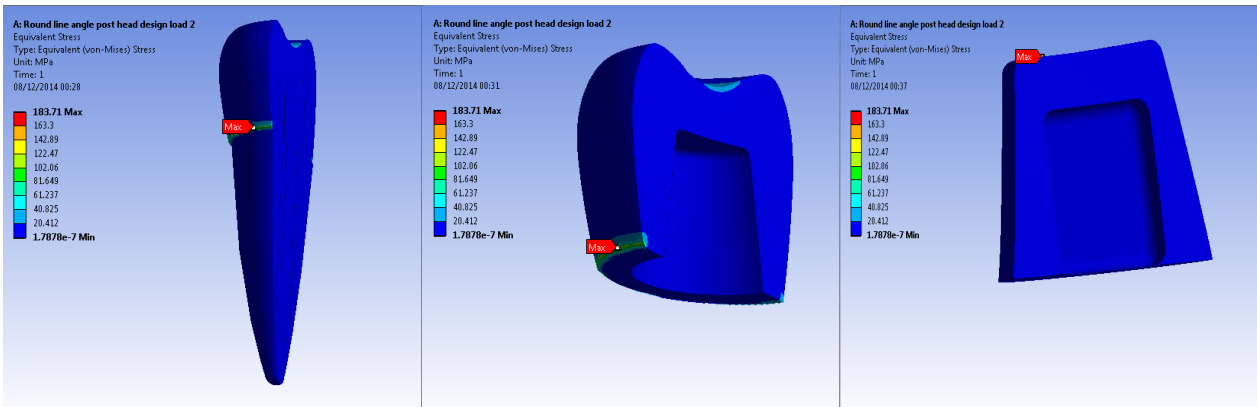

**Figure 8: Maximum Von Mises stress value and pattern of design (B) under LO load; a) all model parts, b) crown, and c) composite core.**

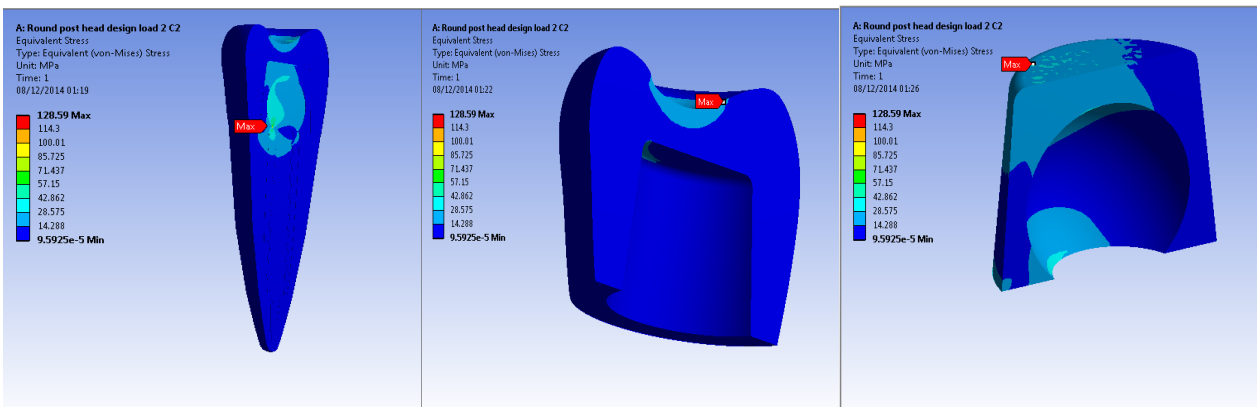

**Figure 9: Maximum Von Mises stress value and pattern of design (C) under LO load; a) all model parts, b) crown, and c) composite core.**

this study could be considered as a base for more practical and clinical studies. This is an innovative approach need to be considered and investigate, when designing or using any dental post screw. However, there are other post screw materials available now a day in the market (titanium, carbon fiber and zircon), this study, investigated the geometric shape of the post screw head prefabricated from stainless steel which, was still widely used by dentists. Although, the core shape, build-up is different according to the tooth position in the oral cavity, a single root canal upper second premolar was chosen to investigate in this study to simplify the model. Although amalgam provides higher strength compared with composite and glass-ionomer<sup>(16-17)</sup>, composite core is simulated in this study, because it is easily placed and manipulate, polymerizing in minutes that allow to prepare the core immediately, less bulk of materials need than dose amalgam to cover the post head, which makes it useful on small teeth. Tjan et al 1993 studied the fracture strengths of amalgam and composite resin cores retained by three types of intradental retentive features were compared with the fracture strength of cores retained by four self-threaded retentive pins. the result predicts that the composite resin cores had significantly greater resistance to fracture than amalgam cores with any of the retentive features<sup>(18)</sup>.

This study results predicts that the post head design C, shown the lowest stress concentration under both load direction compared with design A and B. This may be linked to high stress concentration with the rectangular shape than ball shape of design C<sup>(19)</sup>. From this result, the expectation that higher stress may be concentrated in sharp line angle in the core and crown) in design A and B compared with design C round head shape. This high stress concentrated at the line angle may be act as a predisposing factor to initiate crack in the core structure end with fracture. The highest stress located at the cervical margin of the crown in design A

and B. While design C showed the maximum stress concentrated at the load application site. The crown margin considered the most critical area in the Faulier of the crown. So the high stress at the margin of the crown will lead to degradation of the cement layer or fracture the periphery of the crown margin that may be ended with the leakage. To overcome the high stress at the margin, need to provide more material thickness of the crown margin. On the other hand the maximum stress located at the top surface of the core in design C and distributed toward all the core part apically under V and LO load away from the cervical area of the crown. These results predicted that the round post head design C produce more benign stress distribution under different occlusal load compared with the other two designs. With limitation of this study, the clinical significance of the present study would allow clinicians to make an informed choice from among available post screw post head design that produce good retention and lower stress in the core and crown for endodontically treated teeth.

### Conclusions:

The ball post screw head design produces a more benign stress distribution and lower stress concentration under different occlusal load compared with rectangular shape particularly at the crown margin.

### Acknowledgment:

I would like to acknowledge with gratitude Dr. Laith Abed Sabri for helping us to utilize the finite element software in this study and Dr. Ranjdar Talabani for continuous support

### References:

1. Kokane VB, Patil SN. Post Endodontic Restoration: Are You Serious? *Journal of Dental and Medical Sciences* Nov.- Dec. 2012; 3 (1):04-7.
2. Shillingburg HT, Sather DA, Wilson EL, Cain JR, Mitchell DL, Blanco LJ, et al. *Fundamentals of fixed prosthodontics* Fourth edition ed. edition F, editor. USA: Quintessence Publishing Co.Inc; 2012.
3. Kokane VB, Patil SN. Post Endodontic Restoration: Are You Serious? *Journal of Dental and Medical Sciences*. Nov.- Dec. 2012;3 (1):04-7.
4. Chang W-C, Millstein PL. Effect of design of prefabricated post heads on core materials. *The Journal of Prosthetic Dentistry*. 1993;69(5):475-82.
5. Peroz I, Blankenstein F, Lange K-P, Naumann M. Restoring endodontically treated teeth with posts and cores—a review. *Quintessence Int*. 2005;36(9):737-46.
6. Pereira JR, Mendonça Neto Td, Porto VdC, Pegoraro LF, Valle ALd. Influence of the remaining coronal structure on the resistance of teeth with intraradicular retainer. *Brazilian dental journal*. 2005;16(3):197-201.
7. Guzy GE, Nicholls JI. In vitro comparison of intact endodontically treated teeth with and without endo-post reinforcement. *The Journal of Prosthetic Dentistry*. 1979;42(1):39-44.
8. Trope M, Maltz DO, Tronstad L. Resistance to fracture of restored endodontically treated teeth. *Dental Traumatology*. 1985;1(3):108-11.
9. Morgano SM. Restoration of pulpless teeth: application of traditional principles in present and future contexts. *The Journal of Prosthetic Dentistry*. 1996;75(4):375-80.
10. Heydecke G, Butz F, Strub JR. Fracture strength and survival rate of endodontically treated maxillary incisors with approximal cavities after restoration with different post and core systems: an in-vitro study. *Journal of Dentistry*. 2001;29(6):427-33.
11. Kovarik RE, Breeding LC, Caughman WF. Fatigue life of three core materials under simulated chewing conditions. *The Journal of Prosthetic Dentistry*. 1992;68(4):584-90.
12. Zalkind M, Shkury S, Stern N, Heling I. Effect of prefabricated metal post-head design on the retention of various core materials. *Journal of Oral Rehabilitation*. 2000;27(6):483-7.
13. Cohen BI, Pagnillo MK, Newman I, Musikant BL, Deutsch AS. Retention of a core material supported by three post head designs. *The Journal of Prosthetic Dentistry*. 2000;83(6):624-8.

14. Nelson SJ. *Wheeler's dental anatomy, physiology and occlusion: Elsevier Health Sciences; 2009.*
15. Pérez-González A, González-Lluch C, Sancho-Bru JL, Rodríguez-Cervantes PJ, Iserte-Vilar JL. *Biomechanical Models of Endodontic Restorations. 2011.*
16. Christensen GJ. *Amalgam vs. composite resin: 1998. J Am Dent Assoc. 1998;129(12):1757-9.*
17. van Noort. *Introduction to Dental Materials. Mosby El Siver. 2007;Third Edition:88,118.*
18. Tjan A, Dunn JR, Lee J. *Fracture resistance of amalgam and composite resin cores retained by various intradental retentive features. Quintessence international (Berlin, Germany: 1985). 1993;24(3): 211-7.*
19. Callister WD, Rethwisch DG. *Materials science and engineering: an introduction: Wiley New York; 2007.*